



GOLF ESTATES BEAUTIFICATION MSTU

ADVISORY COMMITTEE

8300 Radio Road
Naples, FL 34104

AGENDA APRIL 20TH, 2023

I. CALL TO ORDER

II. ATTENDANCE

Tony Branco - Chair (10/1/25)
Kathleen Dammert - Vice Chair (10/1/26)
Linda Rae Jorgensen (10/1/25)
Kathleen Slebodnik (10/1/25)
Anita Ashton (10/1/26)

Michelle Arnold – Retired March 31st –
Dan Schumacher – Project Mgr, PTNE Div.
Rosio Garcia, Operations Coord. PTNE Div.
Michael McGee – McGee & Associates
Gary Gorden – Superb Landscape Services
Wendy Warren – Premier Staffing

III. APPROVAL OF AGENDA

IV. APPROVAL OF MINUTES – MARCH 16TH, 2023

V. CHAIRMAN’S REPORT – TONY BRANCO

- A. Community Assessment.
- B. St Andrews Speeds & Traffic Count

VI. CONTRACTOR REPORTS

- A. [Landscape Architect’s Report](#) – M^cGee & Associates (M&A)
- B. Landscape Maintenance Report – Superb Landscape Services (SLS)

VII. PROJECT MANAGER’S REPORT – DAN SCHUMACHER

- A. [Budget Report](#)
- B. [Lighting Inspection Report](#) – Outages & Inspection
- C. Tree Pruning along Rattlesnake Hammock Rd
- D. [Summer Annuals](#)
- E. May Meeting

VIII. ONGOING BUSINESS

- A. St. Andrews Entryway Monuments Refurbishment
- B. Traffic Signage Damage Repairs
 - Donation of signs to the MSTU is required.
- C. Traffic Calming
- D. Pending Items

IX. NEW BUSINESS

- A. Doral Circle Renovation - Median 23
- B. Canal Weir Fence

X. COMMITTEE MEMBER COMMENTS

XI. PUBLIC COMMENT

XII. ADJOURNMENT

NEXT MEETING:

MAY 18, 2023 AT 2:00 PM

South Regional Library
8065 Lely Cultural Pkwy
Naples, FL 34113, (239) 252-7542



GOLF ESTATES BEAUTIFICATION MSTU

ADVISORY COMMITTEE

8300 Radio Road

Naples, FL 34104

Minutes

March 16, 2023

I. Call to Order

The meeting was called to order at 2:01 PM and a quorum of five was present.

II. Attendance

Committee Members: Tony Branco, Chair; Kathleen Dammert, Vice Chair; Anita Ashton, Linda Jorgensen, Kathleen Slebodnik

County: Michelle Arnold, PTNE Director (ZOOM); Dan Schumacher, Project Manager; Rosio Garcia, Operations Coordinator

Others: Mike McGee, Landscape Architect, McGee & Associates; Gary Gorden, Superb Landscape Services; Wendy Warren, Premier Staffing; Lisa McGarity, Resident; Pat McCabe, Resident

III. Approval of Agenda

Vice Chair Dammert moved to approve the Agenda of the Lely Golf Estates Beautification M.S.T.U. Second by Ms. Ashton. Carried unanimously 5 - 0.

IV. Approval of Minutes – February 16, 2023

Ms. Ashton moved to approve the minutes of the February 16, 2023, Lely Golf Estates Beautification M.S.T.U. Second by Vice Chair Dammert. Carried unanimously 5 - 0.

V. Chairman's Report – Tony Branco

A. Community Assessment

Chair Branco reported on observations made during the monthly drive through:

- The front entrance monument renovation project is underway.
- The front entrance landscaping is in satisfactory condition, seasonal flowers display good color, and palms were trimmed.
- Pebble Beach and Forest Hills Boulevards medians look good as did Valley Stream Circle.
- Landscaping at the Pinehurst monument was trimmed.
- The missing geraniums planted on the Doral Circle median will be replanted.

Decayed Wooden Fence along Rattlesnake Hammock Road

Ms. McGarity reported:

- The homeowners at 107 and 109 Willow Creek Lane were notified to remove damaged fence slats. Removal of debris is complete at 107. Fencing debris at 109 will be removed by March 16th.
- The Road Maintenance Division were contacted to remove Brazilian Pepper plants behind 107 Willow Creek Lane. Work to be completed by March 20, 2023.

B. St Andrews Blvd. Speeds and Traffic Count

Two (2) Traffic Logix SafePace 100 speed monitoring signs are functioning on Saint Andrews Boulevard, eastbound by the Lely Presbyterian Church (*Radar 1*) and westbound at Pine Valley Circle (*Radar 2*).

Chair Branco distributed a daily vehicle report for data from February 14, 2023, to March 14, 2023.

- Radar 1 (110 St Andrews Blvd) recorded 62,205 vehicles averaging 2,145 vehicles per day. The maximum speed was fifty-two (52) mph.
- Radar 2 (255 Saint Andrews Blvd) recorded 68,219 vehicles for an average of 2,352 per day. The maximum speed was sixty-one (61) mph.

VI. Contractor Reports

A. Landscape Architect's Report – McGee & Associates (M&A)

Mr. McGee summarized the "*Lely Golf Estates Landscape Observation Report FY22-23*" dated February 2, 2023.

All locations

Recommend 0-0-22 Sul-Po-Mag (SPM) fertilizer application to all Perennial Peanut beds in April.

Saint Andrews Blvd.

Median #3

- Address 105: Remove Plumbago shrubs, fill in low area with clean topsoil. Replant area with a single row of fourteen (14) yellow African Iris. *Staff is securing a quote.*

Median #4

- Monitor Fox Tail Palms for Ganoderma fungus.

Median #5

- Apply fertilizer to Foxtail palms as specified in the summary report. Tecmangam, a magnesium sulphate product, was recommended by Mr. McGee.

Median #6

- Address 228: Remove Plumbago shrubs. Replant area with a single row of fourteen (14) yellow African Iris.

Valley Stream Circle

Median #13

- Replace one (6) Plumbago shrubs.
- The purple Trumpet tree needs to be replaced. *SLS confirmed the tree was ordered.*

Pebble Beach Boulevard

Medians #15, 16 and 17

- Addresses 40,132 and 116: Replace Plumbago shrubs.

Thorncrest and Briarcliff Lanes

Cul-de-sacs #20 and #21

- Recommend renovation of the cul-de-sacs during the rainy season.
- Remove dead plants and apply a light layer of mulch.

Baltusrol Signs

- Remove all Plumbago shrubs on the outbound side and replant.
- Replant thirty-one (31) Perennial Peanut, Golden Glory, on inbound side.

MINUTES

Doral Circle

- Pull mulch away from base of Iris plants.
- Remove dead Foxtal Palm west of Doral Circle.

Median #23

- Recommend replacement of missing Geraniums and five (5) to six (6) Alyssum annuals.
- Twenty missing Dwarf Red “Fireball” Crown-of-thorn need to be replaced.

Plantings are “on hold” pending Committee review of potential renovation.

Water Usage

- Warren Street
 - February 2023 - 92,865 gallons; no potable water usage.
- Valley Stream
 - February 2023 - 11,780 gallons of potable water.

Committee Discussion:

Gateway Entry Monuments

- The monument entry landscaping should be renovated to complement the refurbished monuments. Discussions continued regarding plant choices that are both aesthetically pleasing and environmentally appropriate for the community.

McGee & Associates will create a design for presentation to the Committee at a future meeting.

Doral Circle Landscape Renovation

- The area is approximately one hundred (100) feet long by fifteen (15) feet wide.
- The sign is twenty-two feet long; a low, dark green shrub to cover the lower sign base is recommended.
- Palms may be replanted in the median, which would entail the existing soil be excavated to approximately 3ft depth and new soil filled to remediate Ganoderma contamination.
- Bougainvillea shrubs and Crown-of-thorns would not be replaced.
- Florida friendly plants will be considered if appropriate for the location.
- The irrigation system will be evaluated.

Ms. McCabe, noting residents do not like the Crown-of-thorns, plans to submit plant material ideas to Mr. Schumacher.

Upon receipt of plant suggestions from the public, McGee & Associates will propose a design layout for renovation of the median to the Committee at a future meeting.

B. Landscape Maintenance Report – Superb Landscape Services (SLS)

Mr. Gorden reported:

- Six (6) pallets of “specialty red” mulch was applied to medians.
- A preventative treatment for Thrips (a granular insecticide) will be applied to the soil around the Plumbago shrubs on Monday March 20, 2023.
- Items suggested in McGee & Associates Summary Report were addressed.
- A “hard” cut back of plant material is scheduled for April.

Mr. Schumacher will direct Superb to proceed with replacement of Plumbago plants.

VII. Project Manager’s Report – Dan Schumacher

A. Budget Report

Lely MSTU Fund Budget 152 dated March 16, 2023

- The FY-23 Millage rate remains constant at 2.0000 mills.
- Current Ad Valorem Tax, Line 1, is \$360,700.00; an increase of 15.38% over FY-22.
- Transfers and Contributions, Line 12, are \$529,428.95; a carryover of unexpended FY-22 funds (minus 5%).
- Total Revenue, Line 13, is \$893,128.95, including investment interest, transfers, and contributions.
- Purchase Orders: (Contractors):
 - Graybar – Lumec LED Retro Fixtures.
 - Hart’s Electrical – Electrical Maintenance and LED Fixtures.
 - Howard Fertilizer.
 - McGee & Associates – Landscape Architecture.
 - McShea Contracting – Paver Crosswalks.
 - The Lump Sum Contract, in the amount of \$49,750.00 has been paid.
 - NR Contractors Inc. – Entryway Monument Refurbishment.
 - The Lump Sum Contract will be paid when the job is completed satisfactorily.
 - Premier Staffing – Transcription Services.
 - Sight N Sound, dba Naples Christmas Lighting – Holiday Decorations.
 - SiteOne Landscape Supply – Irrigation Parts & Pumps.
 - Superb Landscaping Services –
 - Incidentals for landscape refurbishment and miscellaneous.
 - Grounds Maintenance for regularly scheduled tasks and irrigation repairs.
- Operating Expense, Line 34, budgeted at \$333,378.95; with current Commitments of \$134,468.27 Expenditures of \$117,835.61, and a Budget Remainder (unspent operating funds) of \$81,075.07.
- Capital Outlay, Line 36, budgeted at \$338,950.00, has a current Commitment of 149,750.00 to fund the *Entryway Monument Refurbishment Project*.
- Transfer to Fund 111, Line 38, in the amount of \$58,800.00, is for MSTU Staff salaries and accrued County overhead related to MSTU operations.
- Transfer to the Property Appraiser, Line 37, in the amount of \$3,100.00, is for computation of MSTU Ad Valorem data for the tax rolls.
- Transfer to the Tax Collector, Line 39, in the amount of \$8,900.00, is for collection of MSTU millage as part of the annual tax bill, currently 2.0000 mills.
- Reserves, Line 42, in the amount of \$150,000.00, is designated for Insurance and Catastrophic damage repair.
- Total Budget, Line 43, lists FY-23 MSTU budgeted funds at \$893,128.95; with tabulated Commitments of \$284,218.27, Expenditures of \$185,491.86, and a Budget Remainder (total unspent funds) of \$423,418.82. The Budget amount of \$893,128.95 does not change during the fiscal year.

Noted:

- Fund 152 is exclusive to the Lely MSTU and cannot be utilized by outside entities.
- FY-23 millage rate of 2.000 accumulates funds for maintenance of community assets as identified in the Capital Asset Management Plan, updated annually, and special projects.

MINUTES

- If necessary, a budget amendment to meet Operating Expense requirements, consistent with the MSTU ordinance, can be requested upon a motion by the Advisory Committee and executed upon approval by the Board of County Commissioners (BCC).
- The FY-24 Budget process will be initiated in late March 2023.

B. Lighting Inspection Report – Outages & Inspection

- Red entries indicate current lamp outages, gray for outages repaired from the previous report, and purple for Metal Halide lamp replacements.
- One (1) outage was identified in Superb Landscape Services report dated March 6, 2023.
- The twelve (12) LED fixtures at a cost of \$7,293.48, ordered from Graybar, were received.
- The Lumec fixtures will retrofit the ten (10) remaining Metal Halide lamps, repair the light outage and stock one (1) fixture in inventory.

Chair Branco recommended that the single outage be coupled with an LED retrofit service call.

Mr. Schumacher will direct Hart's Electrical to proceed with Lumec retrofit replacements.

C. MSTU Bylaws – February 2023

A copy of the updated and committee approved MSTU Bylaws was included in the meeting Agenda packet for general distribution.

D. St. Andrews US Flag

Mr. Schumacher noted the four (4) foot by six (6) foot American Flag appeared too large when mounted and recommended the three (3) foot by five (5) foot flag continue to be displayed.

E. Mulch and Tree Trimming Rattlesnake Road

Mulch

Six (6) pallets of “Specialty Red” mulch were applied to remaining locations.

Tree Trimming Rattlesnake Hammock Road

The Davey Tree Expert Company submitted estimate #200308-16078797763, dated March 14, 2023, in the amount of \$2,400.00 to prune the trees encroaching into the Right of Way (ROW), overhanging the fence hedgerow sections behind the five (5) houses between Rattlesnake Hammock Road and Willow Creek Lane and remove all debris. Maintenance of Traffic (MOT) for temporary traffic control is not required. The work will commence approximately two (2) weeks after issuance of a Purchase Order (PO).

Ms. Ashton motioned to approve The Davey Tree Expert Company proposal, #200308-16078797763, dated March 14, 2023, in the amount of \$2,400.00 to prune the trees encroaching into the Right of Way (ROW), overhanging the fence hedgerow sections behind the five (5) houses between Rattlesnake Hammock Road and Willow Creek Lane and remove all debris. Second by Vice Chair Dammert. Carried unanimously 5 – 0.

F. Public Utilities Renewal Project (PUR)

Mr. Schumacher distributed a summary document outlining the project boundaries. He noted:

- The PUR project was approved by the Board of County Commissioners (BCC) on January 11, 2022, has been initiated by the County.
- Johnson Engineering is the lead firm for the Design phase.

MINUTES

- Construction will be a sequenced program of replacement and improvement of the existing potable water, wastewater, and stormwater utilities. Additional sidewalks are not currently included in the design.
- Field investigation activities are expected to take ten (10) months to complete.
- All disturbed areas will be restored to pre-existing construction conditions.
- Through traffic will be maintained in the community throughout construction.
- Methods to contact the County for updates on the status of the project include:
 - Website: Lely PUR – Lely PUR (<https://lelypur.com>)
 - Hotline: 239-272-0065
 - Email: info@lelypur.com

VIII. Ongoing Business

A. St. Andrews Entryway Monuments Refurbishment

NR Contractors, Inc. is under contract to refurbish the two (2) Lely Golf Estates community entryway sign monuments at the intersection of St Andrews Blvd & US-41.

- The concrete arch was added to both monuments and the entry side monument back wall has been replaced.
- Precast cap stone samples were approved, and manufacture commenced the week of March 13th.
- Installation of the cap stones by the contractor is expected the week of March 20th.
- Logo & Lettering samples are under review.
- A rendering of the monument renovation will be posted on the MSTU web site.

B. Traffic Signage Damage Repairs

Donation of Decorative Traffic Signs to the MSTU

- Twenty-seven (27) signs damaged by Hurricane Ian need various levels of repair.
- Transfer of ownership of all decorative signs by the Homeowners Association (HOA) to the MSTU is required for MSTU-funded repairs to commence.
- MSTU staff has consulted with the County Attorney's Office on a process for the Lely Civic Assn. to transfer assets and maintenance responsibilities for the LGE traffic signs to the MSTU.
- The Board of County Commissioners (BCC) must approve the ownership transfer.
- Repairs are "on hold" pending resolution of issues with the recently amended Lely Civic Association documents.

HOA Documents

- **Ms. McGarity** reported Homeowner Association (HOA) amended documents, with language eliminating the HOA's easement around the signs, will be distributed for the April 2023 association meeting to enabling the MSTU to assume ownership and financial responsibility for the signs.
- Additionally, broader Civic Assn. claims of jurisdiction over assets and easements within LGE which also conflict with the MSTU or the County, will be amended/corrected in the HOA documents and adopted by the community.

C. Traffic Calming

The consensus of the Committee was to postpone installation of speed bumps until the Public Utilities Renewal (PUR) project is completed.

MINUTES

Ms. McGarity plans to obtain signatures from six (6) owners of transferred properties on Forest Hills Blvd. to satisfy the Traffic Operations Division petition requirement for consideration of speed bump installation.

D. Pending Items

There are no pending items for discussion currently.

IX. New Business

None

X. Committee Member Comments

None.

XI. Public Comments

None

XII. Adjournment

There being no further business to come before the Committee, the meeting was adjourned by the Chair at 3:30 P.M.

**LELY GOLF ESTATES BEAUTIFICATION MSTU
ADVISORY COMMITTEE**

Tony Branco, Chairman

These Minutes were approved by the Committee on _____, 2023 as presented ___ or as amended ___.

NEXT MEETING:

APRIL 20, 2023
SOUTH REGIONAL LIBRARY
8065 LELY CULTURAL PARKWAY
NAPLES, FL 34113
239.252.7542

Count by Speed Range Report

Location: Radar 1

Report period: 2023-03-18 to 2023-04-18

Address: Saint Andrews Boulevard

Count By Speed Range

| Speed (mph) | Count |
|-------------|-------|
| 1-5 | 50 |
| 6-10 | 331 |
| 11-15 | 1565 |
| 16-20 | 6117 |
| 21-25 | 28977 |
| 26-30 | 24186 |
| 31-35 | 4237 |
| 36-40 | 297 |
| 41-45 | 33 |
| 46-50 | 8 |
| 51-55 | 2 |
| 56-60 | 0 |
| 61-65 | 0 |
| 66-70 | 1 |
| 71-75 | 0 |
| 76-80 | 0 |
| 81-85 | 0 |
| 86-90 | 0 |
| 91-95 | 0 |
| 96-100 | 0 |
| Total | 65804 |

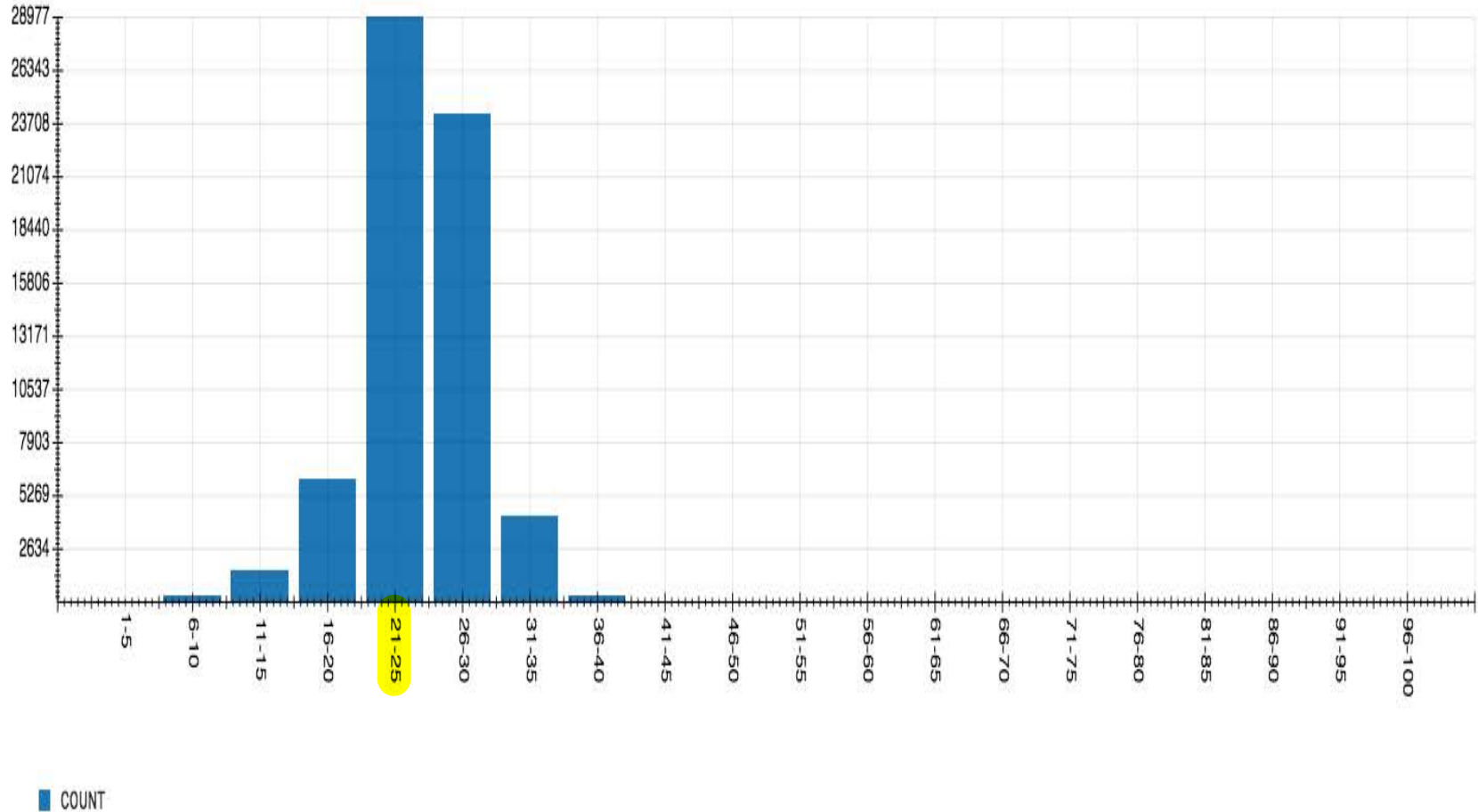

Radar 1 Custom Report

Location: **Radar 1**
 Address: **Saint Andrews Boulevard**
 Speed Limit: From schedule 25 mph

Report Period: 2023-03-18 to **2023-04-18**
 Total Vehicle Count: **65804**

| Date/Time | Total Vehicle | # of Speed Violations | % of Speed Violations | Max Speed (mph) |
|---------------------|---------------|-----------------------|-----------------------|-----------------|
| 2023-03-18 00:00:00 | 2037 | 989 | 0 % | H 66 |
| 2023-03-19 00:00:00 | 1600 | 797 | 0 % | 50 |
| 2023-03-20 00:00:00 | 2269 | 881 | 0 % | 42 |
| 2023-03-21 00:00:00 | H 2340 | 1139 | 0 % | 47 |
| 2023-03-22 00:00:00 | 2234 | 1139 | 0 % | 40 |
| 2023-03-23 00:00:00 | 2279 | 1184 | 0 % | 45 |
| 2023-03-24 00:00:00 | 2328 | 1229 | 0 % | 42 |
| 2023-03-25 00:00:00 | 1930 | 989 | 0 % | 52 |
| 2023-03-26 00:00:00 | 1776 | 923 | 0 % | 41 |
| 2023-03-27 00:00:00 | 2085 | 854 | 0 % | 40 |
| 2023-03-28 00:00:00 | 2202 | 1144 | 0 % | 39 |
| 2023-03-29 00:00:00 | 2185 | 1119 | 0 % | 45 |
| 2023-03-30 00:00:00 | 2168 | 1081 | 0 % | 44 |
| 2023-03-31 00:00:00 | 2326 | 1183 | 0 % | 43 |
| 2023-04-01 00:00:00 | 2017 | 1017 | 0 % | 43 |
| 2023-04-02 00:00:00 | 1707 | 918 | 0 % | 43 |
| 2023-04-03 00:00:00 | 2258 | 1055 | 0 % | 47 |
| 2023-04-04 00:00:00 | 2196 | 1150 | 0 % | 47 |
| 2023-04-05 00:00:00 | 2257 | 1156 | 0 % | 45 |
| 2023-04-06 00:00:00 | 2144 | 1059 | 0 % | 45 |
| 2023-04-07 00:00:00 | 2165 | 1131 | 0 % | 42 |
| 2023-04-08 00:00:00 | 1834 | 1026 | 0 % | 41 |
| 2023-04-09 00:00:00 | 1383 | 743 | 0 % | 42 |
| 2023-04-10 00:00:00 | 1997 | 917 | 0 % | 41 |
| 2023-04-11 00:00:00 | 2195 | 1110 | 0 % | 39 |
| 2023-04-12 00:00:00 | 1973 | 1029 | 0 % | 49 |
| 2023-04-13 00:00:00 | 2176 | 1170 | 0 % | 45 |
| 2023-04-14 00:00:00 | 2183 | H 1241 | 0 % | 51 |
| 2023-04-15 00:00:00 | 1794 | 987 | 0 % | 48 |

| | | | | |
|---------------------|------------|------------|----------|----|
| 2023-04-16 00:00:00 | 1595 | 891 | 0 % | 45 |
| 2023-04-17 00:00:00 | 2060 | 999 | 0 % | 43 |
| 2023-04-18 00:00:00 | 2111 | 1109 | 0 % | 38 |
| Summary | SUM: 65804 | SUM: 33359 | AVG: 0 % | |

Count by Speed Range Report

Location: Radar 2-20120088

Report period: 2023-03-18 to 2023-04-18

Address: 255 Saint Andrews Blvd Naples

Count By Speed Range

| Speed (mph) | Count |
|-------------|-------|
| 1-5 | 279 |
| 6-10 | 1673 |
| 11-15 | 1794 |
| 16-20 | 3550 |
| 21-25 | 10820 |
| 26-30 | 28229 |
| 31-35 | 20000 |
| 36-40 | 4891 |
| 41-45 | 690 |
| 46-50 | 105 |
| 51-55 | 33 |
| 56-60 | 10 |
| 61-65 | 4 |
| 66-70 | 0 |
| 71-75 | 2 |
| 76-80 | 0 |
| 81-85 | 0 |
| 86-90 | 0 |
| 91-95 | 0 |
| 96-100 | 0 |
| Total | 72080 |

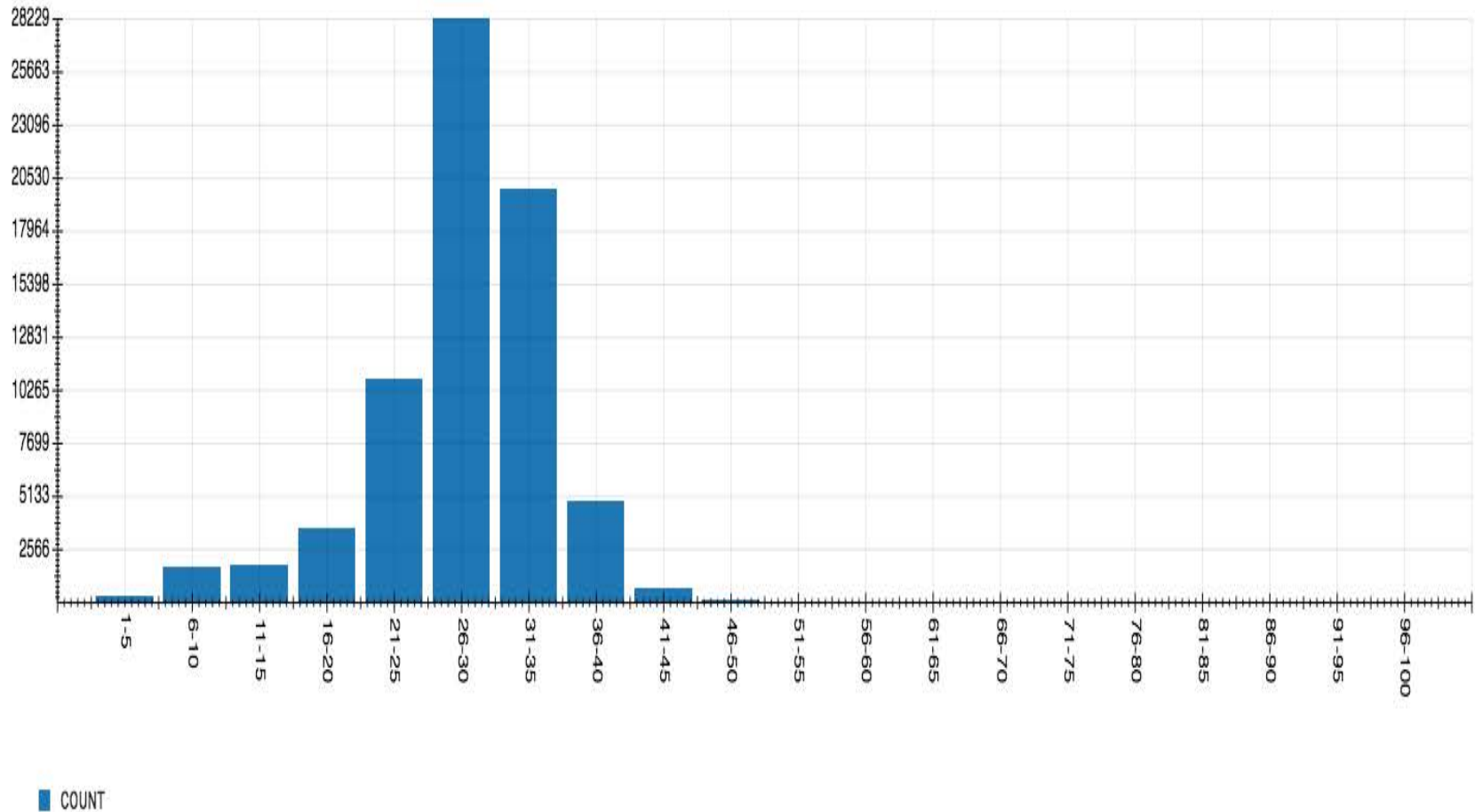

Radar 2 Custom Report

Location: Radar 2 - 20120088
 Address: 255 Saint Andrews Blvd Naples
 Speed Limit: From schedule 25 mph

Report Period: 2023-03-18 to 2023-04-18
 Total Vehicle Count: 72080

| Date/Time | Total Vehicle | # of Speed Violations | % of Speed Violations | Max Speed (mph) |
|---------------------|---------------|-----------------------|-----------------------|-----------------|
| 2023-03-18 00:00:00 | 2063 | 1611 | 0 % | 53 |
| 2023-03-19 00:00:00 | 1670 | 1204 | 0 % | 58 |
| 2023-03-20 00:00:00 | 2526 | 1975 | 0 % | 48 |
| 2023-03-21 00:00:00 | 2562 | 2015 | 0 % | 55 |
| 2023-03-22 00:00:00 | 2400 | 1859 | 0 % | 52 |
| 2023-03-23 00:00:00 | 2420 | 1875 | 0 % | 47 |
| 2023-03-24 00:00:00 | 2563 | 2019 | 0 % | 50 |
| 2023-03-25 00:00:00 | H 2676 | H 2092 | 0 % | 52 |
| 2023-03-26 00:00:00 | 1827 | 1378 | 0 % | 53 |
| 2023-03-27 00:00:00 | 2356 | 1849 | 0 % | 51 |
| 2023-03-28 00:00:00 | 2449 | 1941 | 0 % | 58 |
| 2023-03-29 00:00:00 | 2454 | 1905 | 0 % | 54 |
| 2023-03-30 00:00:00 | 2431 | 1866 | 0 % | 52 |
| 2023-03-31 00:00:00 | 2565 | 2033 | 0 % | 71 |
| 2023-04-01 00:00:00 | 2221 | 1675 | 0 % | 52 |
| 2023-04-02 00:00:00 | 1812 | 1388 | 0 % | 65 |
| 2023-04-03 00:00:00 | 2445 | 1872 | 0 % | 50 |
| 2023-04-04 00:00:00 | 2468 | 1946 | 0 % | 53 |
| 2023-04-05 00:00:00 | 2430 | 1927 | 0 % | 51 |
| 2023-04-06 00:00:00 | 2396 | 1826 | 0 % | 61 |
| 2023-04-07 00:00:00 | 2325 | 1874 | 0 % | 58 |
| 2023-04-08 00:00:00 | 2002 | 1557 | 0 % | H 72 |
| 2023-04-09 00:00:00 | 1496 | 1198 | 0 % | 57 |
| 2023-04-10 00:00:00 | 2167 | 1704 | 0 % | 60 |
| 2023-04-11 00:00:00 | 2246 | 1806 | 0 % | 53 |
| 2023-04-12 00:00:00 | 2132 | 1683 | 0 % | 53 |
| 2023-04-13 00:00:00 | 2267 | 1785 | 0 % | 63 |
| 2023-04-14 00:00:00 | 2398 | 1931 | 0 % | 59 |
| 2023-04-15 00:00:00 | 1956 | 1519 | 0 % | 58 |

| | | | | |
|---------------------|-------------------|-------------------|----------|----|
| 2023-04-16 00:00:00 | 1678 | 1297 | 0 % | 55 |
| 2023-04-17 00:00:00 | 2313 | 1715 | 0 % | 53 |
| 2023-04-18 00:00:00 | 2366 | 1923 | 0 % | 63 |
| Summary | SUM: 72080 | SUM: 56248 | AVG: 0 % | |

McGee & Associates

Landscape Architecture

Project: LELY GOLF ESTATES BEAUTIFICATION, M.S.T.U. **Landscape Architect Observation Report:** April 2023
Location: MSTU DISTRICT ROADWAYS
Project Manager: Dan Schumacher, Collier County Public Services Division, Public Transportation & Neighborhood Enhancements Department
Consultant: McGee & Associates **Consultant's Representative:** Michael A. McGee, rla, isa
Contractor: Superb Maintenance **Contractor's Representative:** Robert Kindelan, Gary Gorden
Report Date: FY22-23, 4/06/2023 **Observation Date:** 4/06/2023

Report No. 6 (FY23)

AC - Indicates major or repeating items recommended to be discussed by the Advisory Committee

S - Indicates items to be addressed by staff. **C** - Indicates items to be addressed by Contractor

Contractor is requested to address items as soon as possible and indicate in **RESPONSE/COMMENTS** column when and which items are corrected.

Note: Copy picture out of comment boxes and then paste to additional sheet if picture is desired in larger size.

| LOCATION/WORK AREA | AC | S | C | R | OBSERVATION & RECOMMENDATIONS | ADDITIONAL COMMENTS |
|--|----|---|---|---|--|--|
| <u>All locations</u> | X | X | | | It is recommended that all Palms and Trees have pruning performed to remove storm damage foliage and to provide corrective pruning. | Strikethrough indicates items that have been addressed or being addressed and will be removed from the next month's report. Yellow highlighting indicates items that need to be addressed as soon as possible for safety issues, potential plant damage or to reduce future maintenance issues. |
| | | X | | 3 | All Plumbago shrub planting locations have sustained multiple degrees foliage loss due to wind burn. These shrubs may not recover. Recommend waiting 30 days from date of the report and then review for replacements. | |
| <u>St. Andrews Blvd. & US 41 Inbound R/W South</u> | | X | | | Bougainvillea shrubs and irrigation heads have been addressed in front of signs in preparation for sign renovations. | |
| <u>Outbound R/W North Suncoast Credit Union side of sidewalk</u> | | X | X | | Remove Oak tree leaf buildup within Perennial Peanut planting between sidewalk and valley gutter between Bougainvillea shrub beds. | |
| | | X | X | | Remove (2) Oak tree volunteer seedlings growing in Allamanda shrubs behind bench. | |
| | | X | X | | Prune all Oak tree branches less than 10 feet over sidewalk. | |
| <u>St. Andrews Blvd. Median #1</u> | | X | | | No major issues observed. | |
| | | X | X | 3 | Turf Areas should be treated for sedge and broadleaf weeds. | |
| <u>Median #2</u> | | X | X | 3 | Turf Areas should be treated for sedge and broadleaf weeds. | |
| <u>Median #3</u> | X | X | X | 5 | At address 105: Recommend removal of all remaining Plumbago shrubs, fill in low area with clean local topsoil (2-3 C.Y.+/-), and replant area with a single row of (14) African Iris 3 gal. size . Existing irrigation layout will need to be adjusted so that coverage is from the back of curbing if Iris installed, | RFQ #2 |
| <u>Median #4</u> | | X | X | 3 | Two west end Foxtail palms are being monitored for signs of Ganoderma fungus. | |
| <u>Median #5</u> | | X | X | 3 | 3rd Foxtail palm from west end: Recommend additional specialty fertilizer applied (i.e. Magnesium Sulfate 0-0-0-16Mg) | Palm Fertilizer |
| <u>Median #6</u> | X | X | X | 5 | At address 228: (26) Plumbago shrubs are defoliated or dead and need to be replaced. Recommended alternative is to remove all remaining Plumbago and replant area with single row of (xx) 3 gal. size Yellow African Iris . Existing irrigation layout will need to be adjusted so that coverage is from the back of curbing if Iris installed, | RFQ #2 |
| | | X | X | 5 | At address 240: (3) Plumbago shrubs need to be replaced with 3 gal. size replacements. | RFQ #1 |

Design * Environmental Management * Planning * Arborist

5079 Tamiami Trail East / P. O. Box 8052 Naples, Florida 34101
 Phone (239) 417-0707 * Fax (239) 417-0708
 LC 098 * FL 1023A

| LOCATION/WORK AREA | AC | S | C | R | OBSERVATION & RECOMMENDATIONS | ADDITIONAL COMMENTS |
|---------------------------------------|----|---|---|---|---|--|
| Median #7 | | X | | | No major issues observed. | |
| Median #8 | | X | X | 2 | Foxtail palm on west end is in decline. Recommend additional specialty fertilizer applied (i.e. Magnesium Sulfate 0-0-0-16Mg) | M&A 3/2/23: Ganoderma confirmed schedule removal. |
| Median #8A | | X | | | No major issues observed. | |
| Median #9 | | X | | | No major issues observed. | |
| Median #10 | | X | | | No major issues observed. | |
| Forrest Hills Blvd Median #11 | | X | | | No major issues observed. | |
| Median #12 | | | | | No major issues observed. | |
| Forest Hills Cart Crossing & Lake | X | X | X | | The Perennial peanut in front of sign is gone. Recommend replanting area with (29) 1 gal. orange flowered Bulbine 'Hallmark' 12" o.c. | RFQ #1 |
| | | X | X | | Sand cordgrass needs to be treated for insects and cutback to remove damaged foliage. | |
| Valley Stream Cr. Median #13 | | X | X | | The north Tabebuia tree with the duckbill staking system has had one of the cables cut which appears to be from hedge trimmer. Cable needs to be repaired and would further recommend that if trimming personal cannot remember cables are present that when the cables extend near, over or into shrubs needing trimming that ¾" or 1" sch. 40 pvc pipe be put over the cables from the ground to the turnbuckles. | |
| | | X | X | 5 | (6) Plumbago shrubs need to be replaced with 3 gal. size. | RFQ #1 |
| | X | X | | 5 | The south purple Trumpet tree was rolled over during the storm. It was observed that the trunk had rotated out of the root ball and may have broken some main roots. Based upon what was observed while the tree was down it is recommended this tree be replaced because it may not ever re-root properly and become secure. | M&A 02/02/23: Total Plumbago needed is (8) , (3) on east side and (5) on west side. RFQ #3 Spec _____. |
| Pebble Beach Blvd. Median #14 | | X | | | No major issues observed. | |
| Median #15 | | X | X | 5 | At address 40: (3) Plumbago shrubs need to be replaced with 3 gal. size. | RFQ #1 |
| Median #16 | | X | | | No major issues observed. | |
| Median #17 | | X | X | | At address 124: If tree staking is not properly installed and not needed then it should be removed, if needed then re-install it correctly. | |
| | | X | X | 5 | At address 132: (12) Plumbago shrubs need to be replaced with 3 gal. size. | RFQ #1 |
| | | X | X | 5 | At address 116: (7) Plumbago shrubs need to be replaced with 3 gal. size. | RFQ #1 |
| Median #18 | | X | | | No major issues observed. | |
| Median #19 | | X | | | The Perennial peanut has been planted twice and it is basically gone again believed to be due to Rabbits. Recommend replanting area with (45) 1 gal. orange flowered Bulbine 'Hallmark', 18" o.c. | RFQ #1 |
| Pebble Beach Blvd. Golf Cart Crossing | | X | X | | All Sider lily plants need to be treated for leaf spot fungus as soon as possible and remove heavily damaged foliage from the bottom up. Do not remove any new sprouts just foliage. | |
| Thorncrest Ln. cul-de-sac #20 | X | X | | | Due to age and amount of decline it is recommended to renovate this cul-de-sac during this rainy season. | M&A 09/08/22: Renovation on hold, Remove dead plants. M&A 11/4/22: (15-20) dwarf Bougainvillea plants are dead, missing or declined and need to be replaced. Replace with Bougainvillea 'Helen Johnson' 3 gal. size |
| Briarcliff Ln. Cu-de-sac #21 | X | X | | | Due to age and amount decline it is recommended to renovate this cul-de-sac during this rainy season. | M&A 09/08/22: Renovation on hold |

| LOCATION/WORK AREA | AC | S | C | R | OBSERVATION & RECOMMENDATIONS | ADDITIONAL COMMENTS |
|------------------------------------|----|---|---|---|---|---|
| Heather Grove Ln. Cul-de-sac #22 | | X | | | (8) Bougainvillea plants on the eastern side have been run over and need to be reviewed for removal. Any replacements would need to wait until rainy season has started. | |
| Baltusrol Signs | | X | X | | Outbound side: Additional mulch is needed around front & back of sign directly and toward Philodendron plants. | Details: _____ |
| | X | X | X | 5 | Outbound side: Remove all Plumbago shrubs and replant area with (11) 3 gal. RFQ #1 size replacements. Replant Perennial peanut area with (31) 1 gal. 'Golden Glory'. plus --> Inbound side: (5) Plumbago shrubs need to be replaced with 3 gal. size. RFQ #1 | M&A 4/6/23: Since there have been issues with Perennial peanut establishing and growing in this location it is recommended that (45) 1 gal. orange flowered Bulbine 'Hallmark' , 18" o.c. be planted to replace peanut. |
| Doral Cr. East R/W | | X | X | | The first Tabebuia tree from Rattlesnake Hammock Rd. needs to be replaced due to previous hurricane damaged. Install (1) Handoanthus chrysotrichus 'Golden Trumpet Tree' , 11'-13' ht., 3.5" cal., 5'-6' spr., 36" B&B or 65 Gal. Single leader trunk. | RFQ #3 |
| West R/W & Rattlesnake Hammock Rd. | | X | | | Recent directional bore installation has created dirt debris all over the brick paver sidewalk and it should be cleaned off. | |
| | | X | X | | The first Foxtail palm west of Doral Cr. along Rattlesnake Hammock has severely declined and should be removed. No Ganoderma was observed but replacement at this time is not recommended due to growth of canopy trees over hanging the area from adjacent residences. | |
| | | X | X | 2 | Pull mulch away from being in contact with Iris plant bases or foliage. | |
| | | X | X | | (5) White African Iris plants are missing along back of sidewalk in front of Podocarpus hedge. Replace with 3 gal. size plants. | RFQ #1 |
| | | X | X | 4 | Along the south side of the Podocarpus hedge the adjacent properties trees were broken up and lifted toward the roadway. The result is that the fence along the property line has sustained multiple areas of damage. Some areas have been repaired by the property owners, with one location that the backside of the Podocarpus hedge was severely pruned to remove debris and repair fence. The damaged fence and repairs have also resulted in fence debris being left in the swale area behind the Podocarpus hedge and it should be removed. There are still lifted trees leaning into the Podocarpus hedge and R.O.W. area from the adjacent properties. It would be recommended that the adjacent property owners be notified that the County intends to prune back and/or remove all tree canopy over the R.O.W. line and Podocarpus hedge. If these canopy trees are not pruned back and/or removed the shading will result in the Podocarpus hedge thinning over time. | M&A 02/02/23: Recommend wood fence debris be picked up along Podocarpus hedge in front of and back of hedge. Recommend all tree or shrubs hanging over the Podocarpus hedge / property or ROW line be pruned back to the fence line. Recommend removal of branches less than or equal to 2" dia. size. M&A 3/2/23: Observed damage fence being removed. |
| Median #23 | | X | X | 3 | All the Geraniums and 5-6 Alyssum annuals are missing from the north end. Replacement is recommended. With the Summer '23 Annuals? | M&A 4/6/23: Generally, all annuals are gone. |
| | | X | X | 5 | (20) Dwarf Red "Fireball" Crown of thorn are missing or need to be replaced. | M&A 11/4/22: The areas of declined plants have expanded and an additional (10-15) replacement plants will be needed. 3 gal. size plants are recommended. M&A 12/4/22 On the southwest end of median Crown of thorn plants were run over. M&A 3/2/23 Plantings on hold until further review by Committee concerning renovation. |

| LOCATION/WORK AREA | AC | S | C | R | OBSERVATION & RECOMMENDATIONS | ADDITIONAL COMMENTS |
|--------------------------------------|----|---|---|---|---|---------------------|
| Median #24 Treasure Point Cul-de-sac | | X | | | No major issues observed. | |
| Warren St. Pumping Station | | | | | See water use schedule. | |
| Valley Stream Cr. Irrigation | | | | | See water use schedule. | |
| Fertilization | | X | X | | Recommend in April to apply to all perennial peanut beds 0-0-22 SPM at manufacturer's recommended rate. | |

Lely Golf Estates Beautification MSTU Reuse Mixing Chamber Annual Water Use thru 3/23

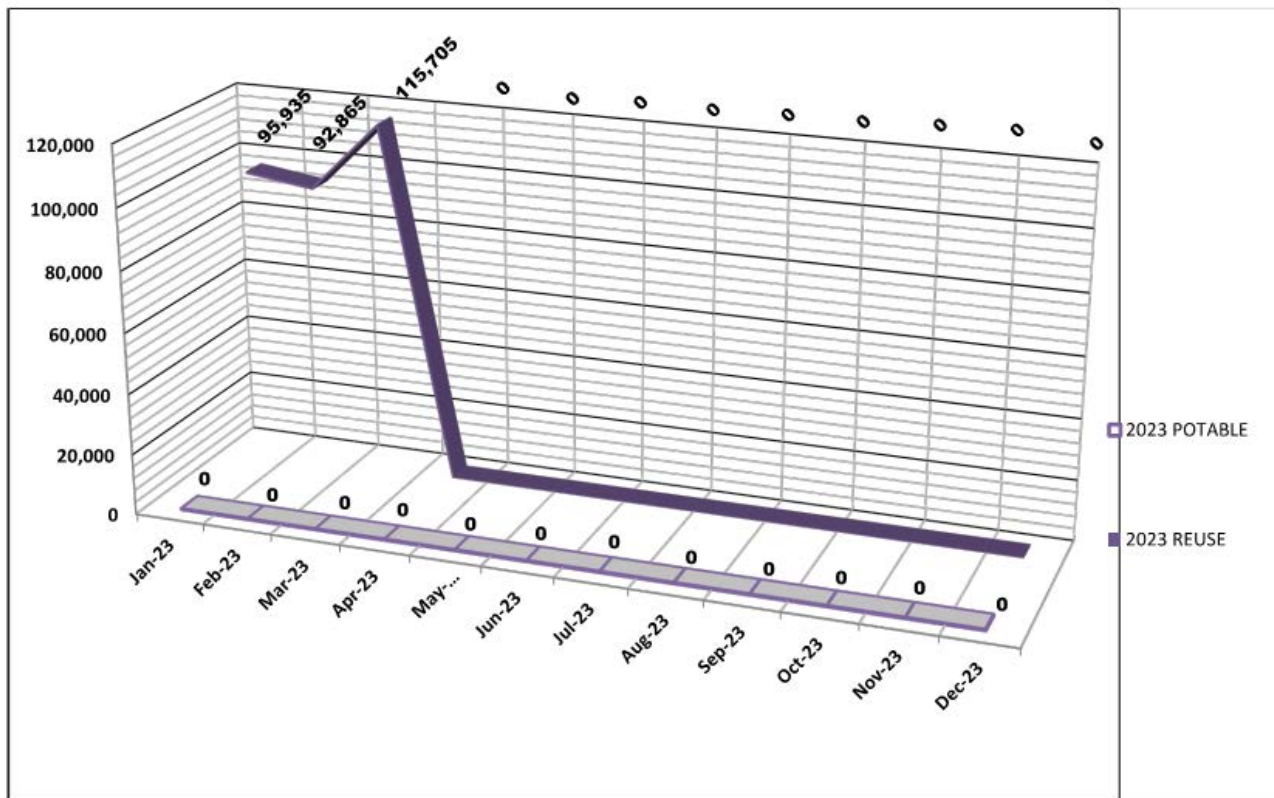

Notes: 2019 Total Water Use: Reuse 1,618,748 gallons, Potable 27,680 gallons
 2020 Total Water Use: Reuse 1,340,040 gallons, Potable 44,945 gallons
 12/2021 New potable water meter installed.
 2021 Total Water Use: Reuse 1,562,060 gallons, Potable 31,740 gallons
 2022 Total Water Use: Reuse 1,591,970 gallons, Potable 64,374 gallons

4/6/2023

| DATE | REUSE PSI | POTABLE WATER METER (X 100) | POTABLE WATER USE GALLONS | REUSE WATER METER READING (X x 100) | REUSE WATER USE GALLONS | TOTAL WATER APPLIED |
|--|-----------|-----------------------------|---------------------------|-------------------------------------|-------------------------|---------------------|
| 3/2/2023 | 85 | 64,300.20 | | 44,088.40 | | - |
| 3/9/2023 | 98 | 64,300.20 | - | 44,326.20 | 23,780.00 | 23,780.00 |
| 3/13/2023 | 105 | 64,300.20 | - | 44,380.95 | 5,475.00 | 5,475.00 |
| 3/24/2023 | 80 | 64,300.20 | - | 44,898.40 | 51,745.00 | 51,745.00 |
| 4/3/2023 | 82 | 64,300.20 | - | 45,245.45 | 34,705.00 | 34,705.00 |
| TOTALS: | | | | 0.00 | 115,705.00 | 115,705.00 |
| PERCENTAGE OF TOTAL VOLUME USED | | | | 0.0% | 100.0% | |

| DATE | POTABLE WATER METER READING (X 1) | POTABLE WATER USE GALLONS |
|-----------|-----------------------------------|---------------------------|
| 3/2/2023 | 407870.07 | |
| 3/13/2023 | 411280.08 | 3410 |
| 3/24/2023 | 415700.07 | 4420 |
| 4/3/2023 | 419660.07 | 3960 |
| | | 11,790 |

LELY GOLF ESTATES M.S.T.U.

Fund 152

April 20, 2023

| | FY-23 | Vendor | Item | PO# | Budget | Commitments | Expenditures | Budget Remainder |
|----|--|---------------------------|---------------------------------|---------------|------------------------|----------------------|------------------------|------------------------|
| 1 | CUR AD VALOREM TAX | | | | \$ (360,700.00) | \$ - | \$ (333,075.86) | \$ (27,624.14) |
| 2 | DEL AD VALOREM TAXES | | | | \$ - | \$ - | \$ - | \$ - |
| 3 | OVERNIGHT INTEREST | | | | \$ - | \$ - | \$ (4,725.10) | \$ 4,725.10 |
| 4 | INVESTMENT INTEREST | | | | \$ (3,000.00) | \$ - | \$ (1,276.21) | \$ (1,723.79) |
| 5 | INTEREST TAX COLL. | | | | \$ - | \$ - | \$ (181.96) | \$ 181.96 |
| 6 | REVENUE STRUCTURE | | | | \$ (363,700.00) | \$ - | \$ (339,259.13) | \$ (24,440.87) |
| 7 | TRANS FROM PROPERTY APPRAISER | | | | \$ - | \$ - | \$ - | \$ - |
| 8 | TRANS FROM TAX COLL | | | | \$ - | \$ - | \$ - | \$ - |
| 9 | CARRY FORWARD GEN | | | | \$ (341,400.00) | \$ - | \$ - | \$ (341,400.00) |
| 10 | CARRY FORWARD OF ENCUMB | | | | \$ (206,328.95) | \$ - | \$ - | \$ (206,328.95) |
| 11 | NEG 5% EST REV | | | | \$ 18,300.00 | \$ - | \$ - | \$ 18,300.00 |
| 12 | TRANSFERS & CONTRIB | | | | \$ (529,428.95) | \$ - | \$ - | \$ (529,428.95) |
| 13 | TOTAL REVENUE | | | | \$ (893,128.95) | \$ - | \$ (339,259.13) | \$ (553,869.82) |
| 14 | ENG. FEES & OTHERS | McGee & Associates | Landscape Architecture | 4500221878 | \$ 29,083.95 | \$ 12,557.25 | \$ 5,562.75 | \$ 10,963.95 |
| 15 | ABSTRACT FEES | | | | \$ - | \$ - | \$ - | \$ - |
| 16 | INDIRECT COST REIMBURSE | Collier County | Indirect Cost | Direct Pay | \$ 7,200.00 | \$ 3,600.00 | \$ 3,600.00 | \$ - |
| | INTERDEPT PAYMENT | | Sign Monument Easements | | \$ - | \$ - | \$ 408.00 | \$ (408.00) |
| 17 | LANDSCAPE INCIDENTALS | Superb Landscape Services | Landscape Incidentals | 4500220470 | \$ 40,000.00 | \$ 38,215.00 | \$ 1,785.00 | \$ - |
| 18 | OTHER CONTRACTUAL (999) | Superb Landscape Services | Grounds Maintenance | 4500220470 | \$ 125,000.00 | \$ 39,040.00 | \$ 50,960.00 | \$ 35,000.00 |
| | | | Pcard | | \$ - | \$ - | \$ 61.10 | \$ - |
| | | McShea Contracting | Paver Style Crosswalks | 4500216252 | \$ - | \$ - | \$ 49,495.00 | \$ - |
| | | Davey Tree Expert | Tree Pruning | 4500224112 | \$ - | \$ 2,400.00 | \$ - | \$ - |
| 19 | OTHER CONTRACTUAL (990) | | | | \$ 74,495.00 | \$ 2,400.00 | \$ 49,556.10 | \$ 22,538.90 |
| 20 | ELECTRICITY | FPL | Electricity | 4700004739 | \$ 4,000.00 | \$ 1,985.84 | \$ 2,014.16 | \$ - |
| 21 | WATER AND SEWER | Collier County Utilities | Water - Irrigation | 4700004740 | \$ 10,000.00 | \$ 4,483.64 | \$ 4,016.36 | \$ 1,500.00 |
| 22 | INSURANCE GENERAL | Collier County | Insurance General | Direct Pay | \$ 600.00 | \$ 300.00 | \$ 300.00 | \$ - |
| 23 | SPRINKLER SYSTEM | SiteOne | Irrigation Parts & Pumps | 4500220473 | \$ 3,000.00 | \$ 1,881.79 | \$ 618.21 | \$ 500.00 |
| 24 | MULCH | Forestry Resources | | Pcard | \$ 5,000.00 | \$ - | \$ 2,998.92 | \$ 2,001.08 |
| | | Graybar | Lumec LED Retro Fixtures | 4500222912 | \$ - | \$ - | \$ 7,293.48 | \$ - |
| | | Hart's Electrical | Electrical Repairs | 4500220480 | \$ - | \$ 4,674.60 | \$ 1,325.40 | \$ - |
| 25 | LIGHTING MAINTENANCE | | | | \$ 15,000.00 | \$ 4,674.60 | \$ 8,618.88 | \$ 1,706.52 |
| 26 | LICENSE & PERMITS | | | | \$ 2,000.00 | \$ - | \$ 102.89 | \$ 1,897.11 |
| | | Premier Staffing | Transcription (FY23) | 4500220472 | \$ - | \$ 1,301.90 | \$ 1,277.10 | \$ - |
| | | Sight N Sound LLC | Holiday Decorations | 4500221732 | \$ - | \$ - | \$ 3,800.00 | \$ - |
| | | Amazon | Holiday Lights | Pcard 5535-49 | \$ - | \$ - | \$ 9.89 | \$ - |
| | | Special Service | American Flags | | \$ - | \$ - | \$ 355.10 | \$ - |
| 27 | OTHER MISCELLANEOUS | | | | \$ 11,000.00 | \$ 1,301.90 | \$ 5,442.09 | \$ 4,256.01 |
| 28 | OFFICE SUPPLIES | | | | \$ 100.00 | \$ - | \$ - | \$ 100.00 |
| 29 | COPYING CHARGES | J.M. Todd | Copier CPC | 4500221236 | \$ 200.00 | \$ 94.81 | \$ 105.19 | \$ - |
| 30 | FERT HERB CHEM | Howard Fertilizer | | Pcard 5515-11 | \$ 3,500.00 | \$ - | \$ 1,123.52 | \$ 2,376.48 |
| 31 | OTHER OPERATING | | | | \$ 200.00 | \$ - | \$ - | \$ 200.00 |
| 32 | TRAFFIC SIGNS | National Traffic Sgins | | Pcard 5513-5 | \$ 3,000.00 | \$ - | \$ 2,228.00 | \$ 772.00 |
| 33 | OPERATING EXPENSE | | | | \$ 333,378.95 | \$ 110,534.83 | \$ 139,440.07 | \$ 83,404.05 |
| 34 | IMPROVEMENTS GENERAL | NR Contractors Inc. | Entryway Monuments | 4500217688 | \$ 338,950.00 | \$ 149,750.00 | \$ - | \$ 189,200.00 |
| 35 | CAPITAL OUTLAY | | | | \$ 338,950.00 | \$ 149,750.00 | \$ - | \$ 189,200.00 |
| 36 | TRANS FROM FUND 152 TO FUND 111 | | Reimbursement for Staff Support | | \$ 58,800.00 | \$ - | \$ 58,800.00 | \$ - |
| 37 | TRANS FROM FUND 152 TO PROPERTY APPRAISER | | | | \$ 3,100.00 | \$ - | \$ 2,055.92 | \$ 1,044.08 |
| 38 | TRANS FROM FUND 152 TO TAX COLLECTOR | | | | \$ 8,900.00 | \$ - | \$ 7,661.52 | \$ 1,238.48 |
| 39 | TRANSFERS | | | | \$ 70,800.00 | \$ - | \$ 9,717.44 | \$ 2,282.56 |
| 40 | RESERVES FOR CONTINUING OPERATIONS - INSURANCE | | | | \$ 150,000.00 | \$ - | \$ - | \$ 150,000.00 |
| 41 | RESERVES | | | | \$ 150,000.00 | \$ - | \$ - | \$ 150,000.00 |
| 42 | TOTAL BUDGET | | | | \$ 893,128.95 | \$ 260,284.83 | \$ 207,957.51 | \$ 424,886.61 |

LELY GOLF ESTATES M.S.T.U.

Fund 152

April 20, 2023

| | | |
|----------------------|----------------------------------|------------------|
| 95,871,609 | FY 12 Final Taxable Value | |
| 92,697,303 | FY 13 Final Taxable Value | -3.3% |
| 95,718,423 | FY 14 Final Taxable Value | 3.3% |
| 99,596,489 | FY 15 Final Taxable Value | 4.1% |
| 106,888,467 | FY 16 Final Taxable Value | 7.3% |
| 116,823,687 | FY 17 Final Taxable Value | 9.3% |
| 127,802,080 | FY 18 Final Taxable Value | 9.4% |
| 135,136,761 | FY 19 Final Taxable Value | 5.7% |
| 142,494,654 | FY 20 Final Taxable Value | 5.4% |
| 152,194,183 | FY 21 Final Taxable Value | 6.8% |
| 156,289,928 | FY 22 Final Taxable Value | 2.7% |
| \$180,331,047 | FY 23 Gross Taxable Value | |
| 15.38% | Adjustment FY 22 to FY 23 | |
| | FY 23 Gross Taxable Value | FY 22 |
| Millage | 2.0000 | 2.0000 |
| Tax Dollars | \$360,662 | \$312,580 |

| | | |
|-------------------------------------|-----------|-------------------|
| Total Available Balance | \$ | 424,886.61 |
| Plus Committed And Not Spent | \$ | 260,284.83 |

| | | |
|-----------------------|-----------|-------------------|
| Estimated Cash | \$ | 685,171.44 |
|-----------------------|-----------|-------------------|

| | | |
|----------------------------|-----------|-------------------|
| Estimated Cash Less | \$ | 657,547.30 |
| Uncollected Taxes | | |

Prepared on 4/11/23

2.0 mill cap
+\$48,082 0.00%

Lely Beautification MSTU

| <u>LELY MSTU LIGHTING INSPECTION</u> | | <i>Inspection Date:</i> | | | 4/5/2023 | |
|---|-----------|--------------------------------|----------|----------|---|----------|
| ST. ANDREWS ENTRANCE - FROM US-41 | | | | | | |
| TUBE | | A | B | C | D | E |
| Sign - Enter | 1 | | | | | |
| Sign - Exit | 2 | | | | | |
| SPOT | | ○ | A | B | Notes | |
| Flagpole - US | 1 | | | | <ul style="list-style-type: none"> ▪ Current outages are sequenced in RED. ▪ Outages repaired in the past month are sequenced in GRAY. ▪ Dim Metal Halide replacements in PURPLE. | |
| Flagpole - FL | 2 | | | | | |
| Flagpole - BCC | 3 | | | | | |
| LUMINAIRE | | ○ | A | B | | |
| Single | 1 | | | | | |
| Single | 2 | | | | | |
| Single | 3 | | | | | |
| Single | 4 | | | | | |
| Single | 5 | | | | | |
| Single | 6 | | | | | |
| Single | 7 | | | | | |
| Single | 8 | | | | | |
| Single | 9 | | | | | |
| Single | 10 | | | | | |
| Single | 11 | | | | | |
| PEBBLE BEACH BLVD | | | | | | |
| LUMINAIRE | | ○ | A | B | | |
| Double | 1 | | | | | |
| Double | 2 | | | | | |
| Double | 3 | | | | | |
| Double | 4 | | | | | |
| Double | 5 | | | | | |
| Double | 6 | | | | | |
| Double | 7 | | | | | |
| Double | 8 | | | | | |
| Double | 9 | | | | | |
| Double | 10 | | | | | |
| Double | 11 | | | | | |
| Double | 12 | | | | | |
| Double | 13 | | | | | |
| Double | 14 | | | | | |
| Double | 15 | | | | | |
| Double | 16 | | | | | |
| Double | 17 | | | | | |
| Double | 18 | | | | | |
| Double | 19 | | | | | |
| Double | 20 | | | | | |
| Double | 21 | | | | | |
| Single | 22 | | | | | |
| Single | 23 | | | | | |

1909

Lely Beautification MSTU

| <u>LELY MSTU LIGHTING INSPECTION</u> | | | 4/5/2023 | | <u>Notes</u> |
|---|----|----|-----------------|---|---------------------|
| FOREST HILLS @ AUGUSTA | | | | | |
| 'LELY' SIGN | | ● | A | B | |
| Solar Light | -- | | | | |
| DORAL CIRCLE | | | | | |
| TUBES | | ● | A | B | |
| Sign - Enter | 1 | | | | |
| Sign - Exit | 2 | | | | |
| LUMINAIRE | | ● | A | B | |
| Double | 1 | | MH | | |
| Double | 2 | | 1 | | |
| Single | 3 | 2 | | | |
| Single | 4 | MH | | | |
| Single | 5 | MH | | | |
| Single | 6 | MH | | | |

1909

BUTTERFLY WHITE



BUTTERFLY LAVENDER SHA



BUTTERFLY DEEP PINK



PLANTING SCHEME B



CORA DEEP LAVENDER

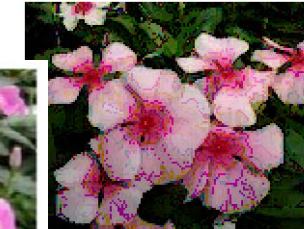

CORA STRAWBERRY



CORA PINK

PLANTING SCHEME A

SUGGESTED PLANTING SCHEMES:

YEAR-ROUND OR JUNE PLANTING DATE:

SCHEME A:

BED #1 - PENTUS VINCA - WHITE

BED #2,3 & 4 - PENTUS-LAVENDER SHA & DEEP PINK MIX

YEAR-ROUND OR JUNE PLANTING DATE:

SCHEME B:

BED #1 - VINCA - CORA DEEP LAVENDER

BED #2,3 & 4 - VINCA CORA STRAWBERRY & PINK MIX

JUNE PLANTING DATE:

SCHEME C:

BED #1,2,3&4 - CALADIUMS - MIX RED & WHITE

CROSSANDRA - ORANGE

COLEUS - KONG ROSE

FLORIDA SWETHEART



RED RUFFLES

BLUSHING BRIDE



WHITE DELIGHT

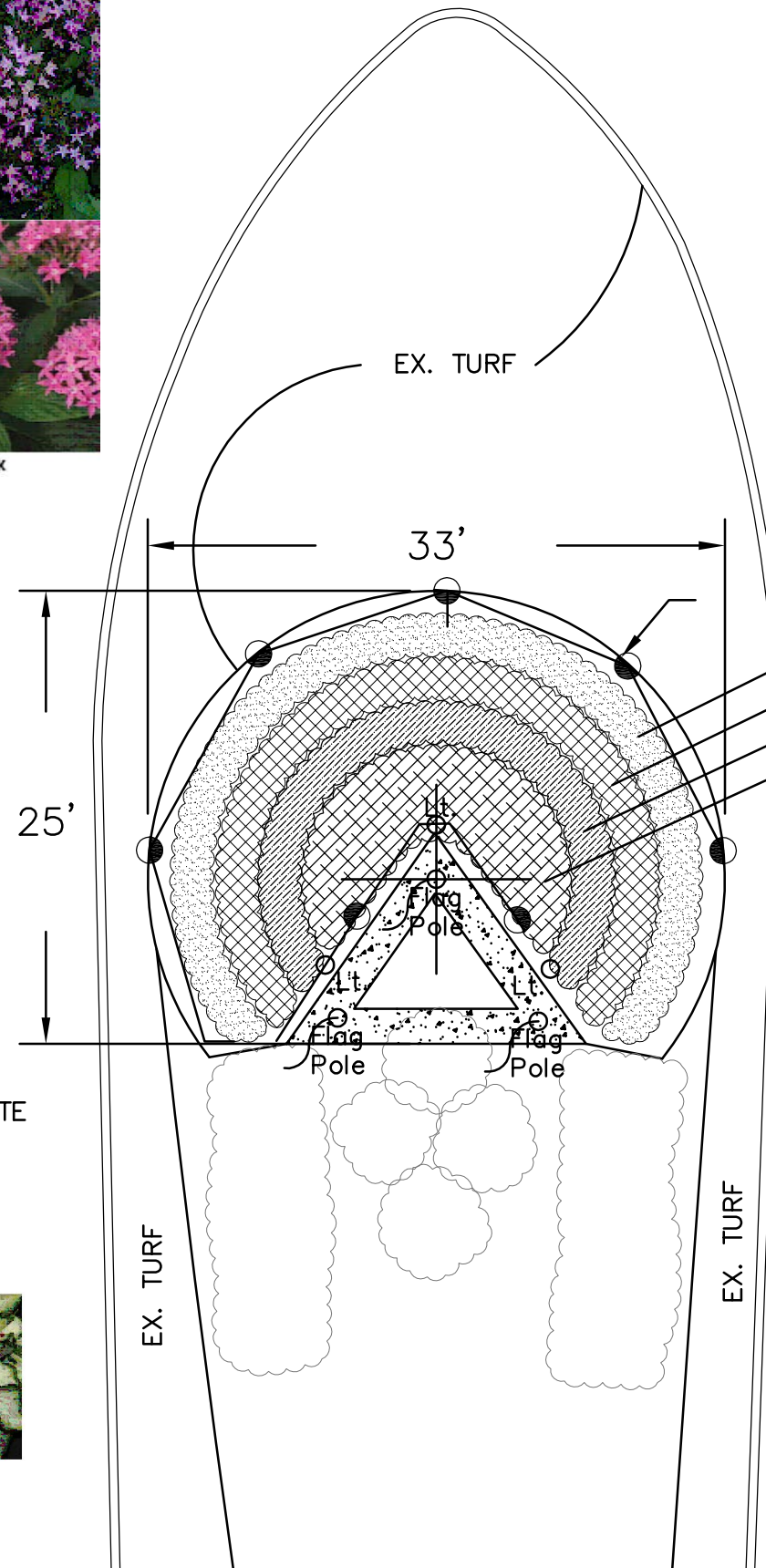
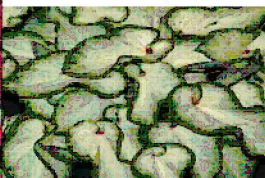

- BED #1, 2-ROWS (128) PLANTS 1' O.C.
 - BED #2, 2-ROWS (105) PLANTS 1' O.C.
 - BED #3, 2-ROWS (81) PLANTS 1' O.C.
 - BED #4, 5-ROWS (98) PLANTS 1' O.C.
- TOTAL PLANTS: (412)



KONG ROSE

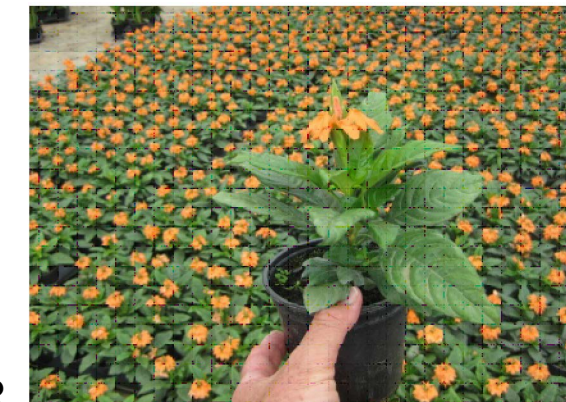

CROSSANDRA

PLANTING SCHEME C

| REVISIONS | | DESCRIPTION |
|-----------|----|-------------|
| DATE | BY | |
| | | |

McGee & Associates
 Landscape Architecture
 DESIGN • ENVIRONMENTAL MANAGEMENT • PLANNING
 5079 Tamiami Trail East • Naples, Florida 34113
 Phone: (239) 417-0707 Fax: (239) 417-0708
 Certificate of Authorization LC-000088 - Michael A. McGee, LA-0000884

COLLIER COUNTY DEPARTMENT OF
 ALTERNATE TRANSPORTATION MODES
 LELY GOLF ESTATES
 BEAUTIFICATION, M.S.T.U.

ST. ANDREW BLVD.
 MEDIAN #1 ANNUAL PLANTINGS
 SUMMER CONCEPT PLAN

| |
|-----------|
| SHEET NO. |
| L-1 |

THESE PLANS AND TECHNICAL DRAWINGS REMAIN THE COPYRIGHT PROPERTY OF THE DESIGNER. NO PART OF THESE DRAWINGS MAY BE COPIED OR REPRODUCED OR BUILT OR USED WITHOUT THE WRITTEN PERMISSION OF McGee & Associates. © 2016